



 **MURTFELDT**

INFORMATION ABOUT TENSIONING SYSTEMS

Contents

01 Basics of a Chain Drive – Wear Elongation	04–07
02 Drive Configuration	08–10
03 Selecting the Right Chain Tensioning System	11–15
04 Advantages of the MURTFELDT Spann-Box®	15

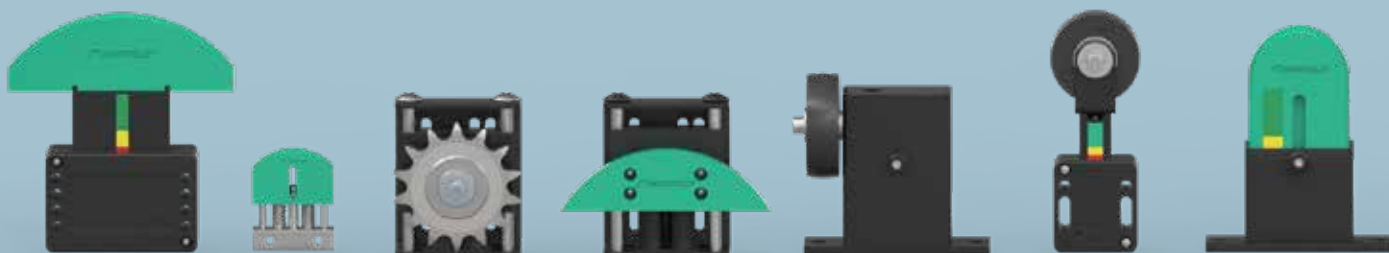

CHAIN TENSIONING SYSTEMS

Design and Operation

Chains are among the most critical wear parts in many systems and machines. Due to constant movement, they are subjected to very high loads, which causes the chain links to stretch and results in increasingly erratic operation. Chain tensioning systems from MURTFELDT reliably maintain chain tension, thereby ensuring optimal operating conditions. Proper design and maintenance of chain drives significantly reduce the risk of failure and extend service life.



01

Basics of a Chain Drive – Wear and Stretch

As the chain circulates around the sprocket, it is subjected to varying loads. Power is transmitted exclusively in the so-called drive run, where the chain is pulled by the drive sprocket. On the opposite side of the chain, the chain moves away from the drive sprocket and is unloaded. This section is referred to as the idler run.

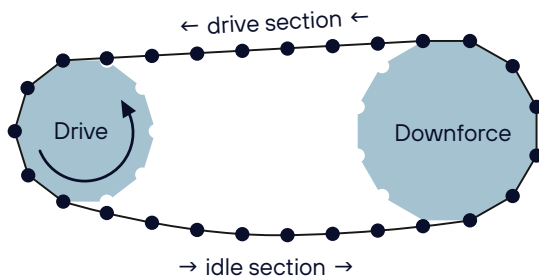

DRIVE SECTION AND IDLE SECTION

In the drive section, the chain moves toward the drive sprocket. Load transmission occurs exclusively in this section of the chain. In the idle section, the chain moves toward the idler sprocket.

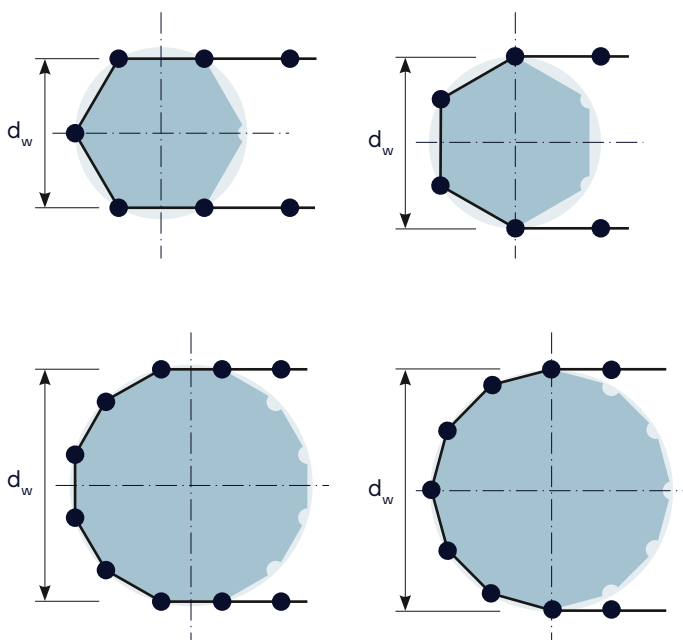

POLYGON EFFECT

A chain wraps around the sprockets in a polygonal pattern. As a result, the effective diameter d_w of the sprocket and consequently the chain speed fluctuates. This irregularity in the chain's forward speed is called the polygon effect, which can lead not only to erratic chain movement and vibrations in the drive, but also to high additional forces and thus to premature chain failure. The fewer the teeth on the sprocket, the greater the percentage difference in speed.

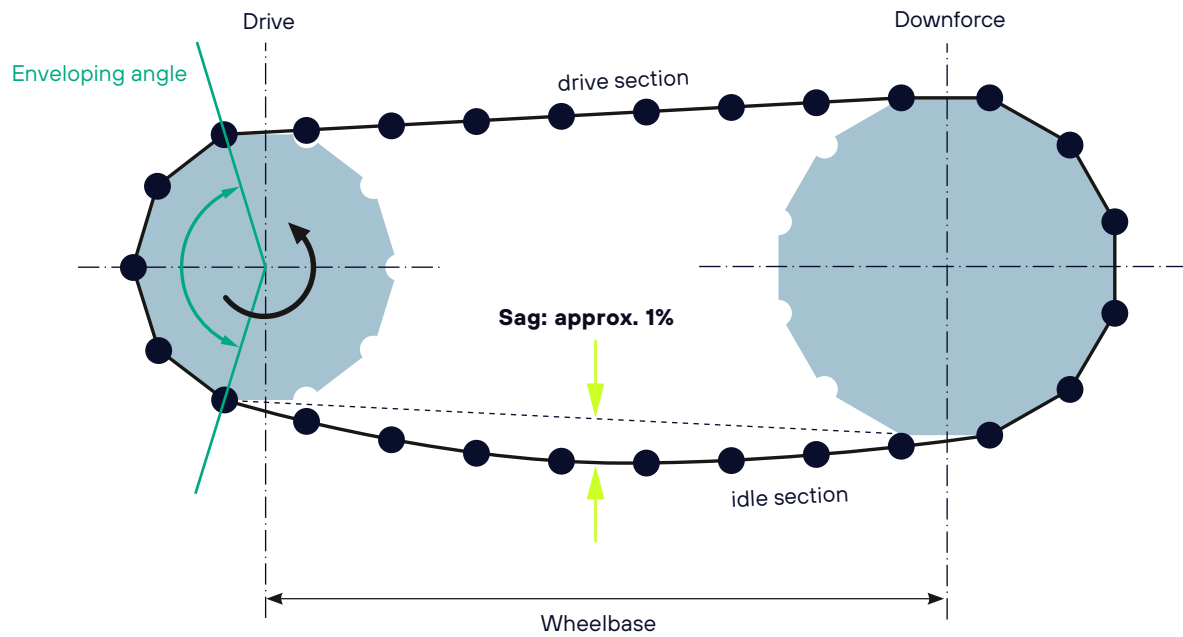

Due to the polygon effect in the chain strand, the link lengths change periodically during operation, which is why a slack in the chain's slack link is absolutely necessary. This slack should be between 1% and 3% of the pitch to prevent additional stress on the chain.

The break-in and wear behavior of roller chains causes continuous elongation and thus increasing slack over time.

Since a roller chain can only tolerate a limited amount of elongation, compensation must be provided for the resulting elongation. A chain can function properly despite wear-induced elongation, provided it is continuously retensioned and thus continues to operate in the intended condition. If, however, the chain is not maintained or retensioned, the slack in the idle section increases progressively, resulting in insufficient chain tension.



PERMISSIBLE SLACK IN ROLLER CHAINS:

3 % for standard drives

2 % for heavy-duty drives

1 % for special applications
such as synchronous
operation or positioning

If the **chain tension is too low**, the wrap angle of the chain around the sprockets is reduced, which can cause the chain to skip over the teeth. This skipping of the chain causes a deviation in timing, for example in positioning drives, and can potentially lead to a break. In addition to increased noise, insufficient chain tension also results in rough chain operation, which further accelerates wear.

If the **chain tension is too high**, the increased pressure on the joint surfaces causes greater friction in the chain joint, thereby accelerating chain wear. Due to the high chain tensile force, other machine components such as the sprocket, bearings, etc., are also subjected to greater stress in addition to the chain, thereby shortening their service life. Friction marks on the chain rollers are a sign of excessive tension.

Enveloping angle

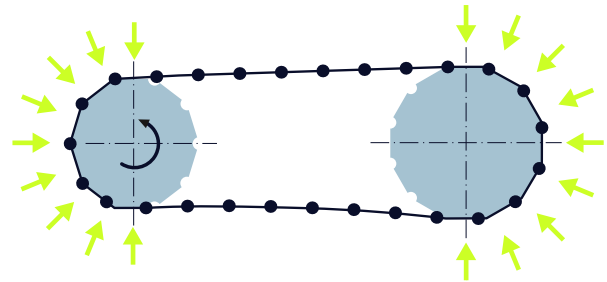
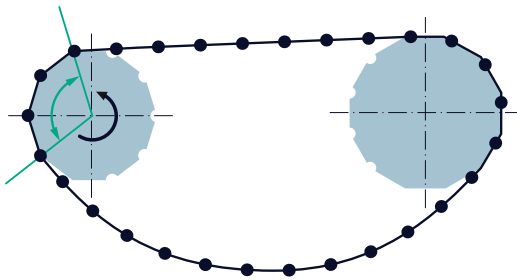

→ **INCORRECT CHAIN TENSION WILL INEVITABLY LEAD TO INCREASED WEAR.**

The chain tension must be adjusted so that the chain operates under dynamic preload even in the idler section. To ensure optimal operation, chain tensioning systems can be used. In addition to regulating the wrap angle, these

systems can also prevent chain vibration and compensate for increasing wear-induced elongation. This prevents the chain from jumping over the sprocket teeth and maximizes the service life of the chain drive.

Various chain tensioning systems based on their operational behavior

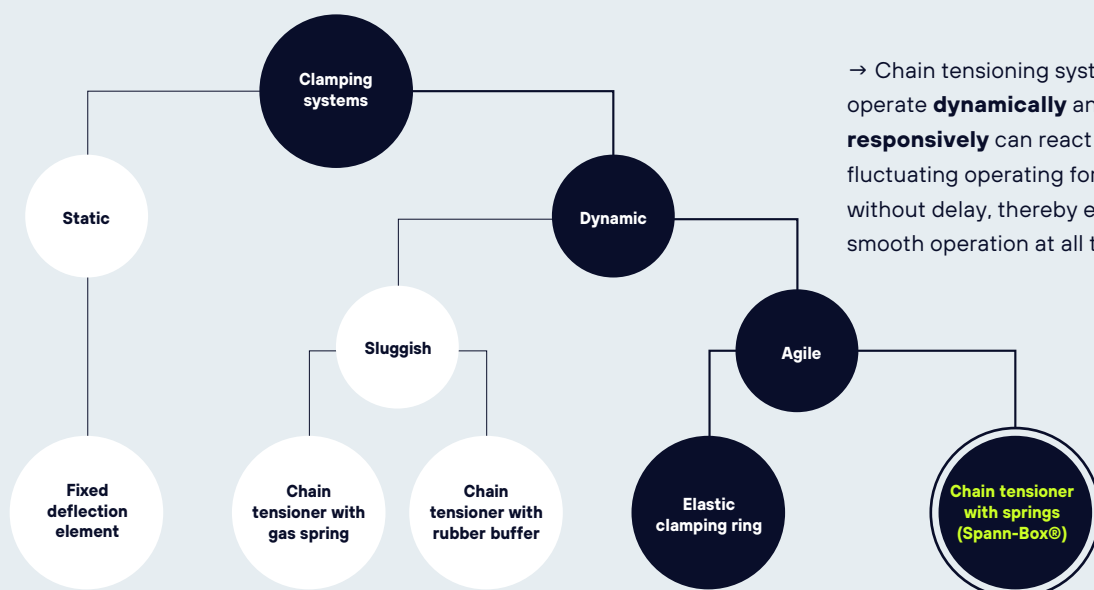

→ Chain tensioning systems that operate **dynamically** and **responsively** can react to fluctuating operating forces without delay, thereby ensuring smooth operation at all times.

With an automatic chain tensioner from MURTFELDT, a chain can be guided either via a sprocket or via a slide profile made of high-performance plastic. While

sprockets are better suited for high speeds (≥ 1 m/s), slide profiles offer the following advantages:

ADVANTAGES OF THE SLIDING PROFILE OVER THE CHAIN SPROCKET

- ✓ As many rollers as possible are in contact
 - minimal to no polygon effect
 - smooth running and reduced wear
- ✓ Protection of the chain links
- ✓ Safe chain guidance
- ✓ Lower noise levels thanks to the sliding profile's damping properties
- ✓ No corrosion

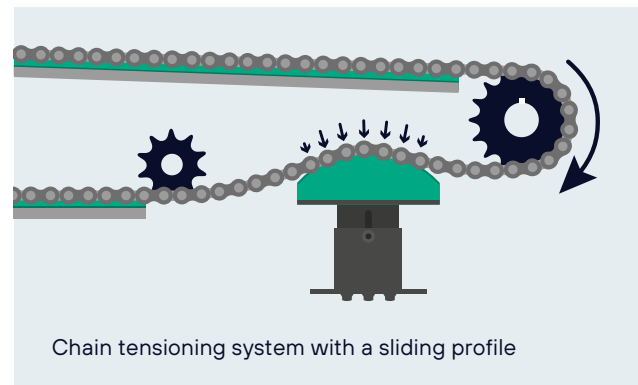
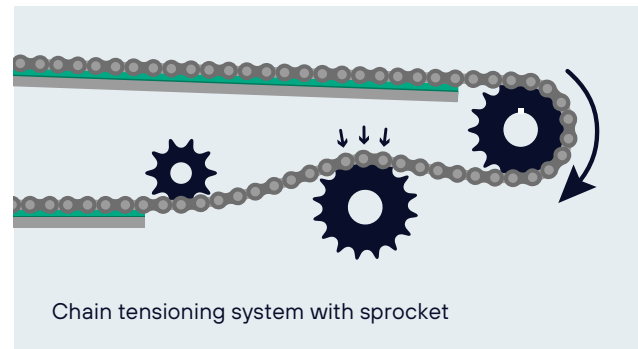

02

Drive Configuration

To achieve the optimal configuration for a chain drive, various parameters must be taken into account, such as the length of the chain, the force to be transmitted, and the available installation space. In general, a horizontal orientation of the sprocket axes is preferable, with the driven run at the top and the free run at the bottom. In this case, the load in the longitudinal direction of the chain has a beneficial effect due to the influence of the chain's own weight, and the chain is guided well into the sprocket teeth. An upper idler strand is only permissible with short center distances and minimal slack.

An inclined arrangement of the sprocket axis up to a 60° angle from the horizontal is also considered a favorable position. Larger angles or a vertical arrangement, on the other hand, represent unfavorable drive configurations due to the poor engagement conditions of the lower sprocket, requiring auxiliary means for the necessary chain tension. Often, the theoretically most favorable relative position of the sprockets cannot be implemented in the design of a chain drive.

THE CORRECT POSITION OF THE CHAIN TENSIONER

By correctly positioning the chain tensioner, wear elongation can be minimized, thereby maximizing the service life of the chain drive. A chain tensioner should always be mounted in the slack section. It is optimal to mount chain tensioner sprockets and chain tensioners immediately behind the drive sprocket to keep the length of the slack section to be tensioned as short as possible.

THE TENSION OF THE CHAIN

is not a determining factor in the design of a chain tensioner; rather, it is the force acting perpendicular to the chain tensioner such as the chain's own weight that is decisive.

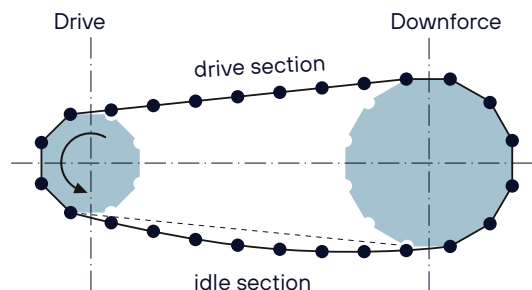

Horizontal configuration with the load located at the top (cost-effective)

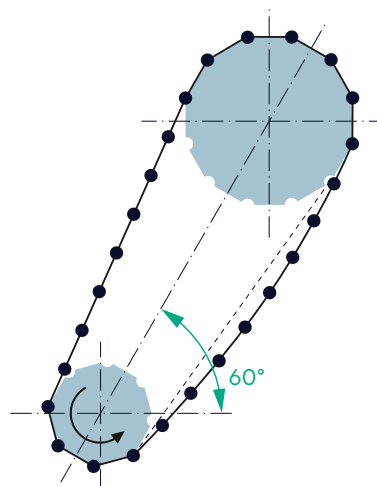

Can be mounted at an angle of up to 60° from the horizontal (convenient)

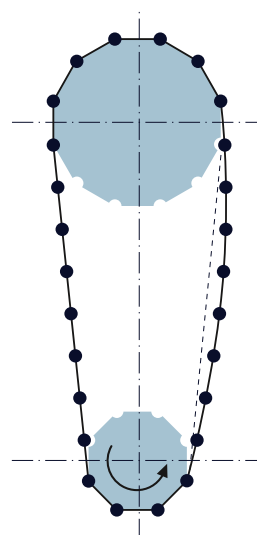

Vertical arrangement of the sprockets (unfavorable)

DIFFERENT DRIVE CONFIGURATIONS

CHAIN DRIVE WITHOUT A CHAIN TENSIONING SYSTEM | DISADVANTAGES

- + Rough running
- + Increasing slack in the chain
- + Rapidly increasing chain wear
- + Increasing noise
- + Vibrations that can cause the chain to skip and the chain link to break



CHAIN DRIVE WITH CHAIN TENSIONING SYSTEM

Chain tensioner located in the slack section immediately behind the drive sprocket, in combination with guide rails. Optimal and highly efficient chain support and tensioning.

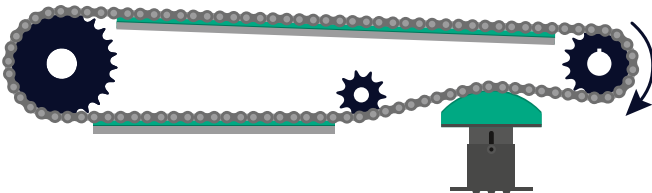

REVERSIBLE OPERATION

Two Spann-Box® units near the drive. When the direction of travel changes, we recommend using two chain tensioners near the drive, as the loaded and unloaded sides switch when the drive direction is reversed. For optimal guidance and increased durability, we also recommend using a deflection profile.

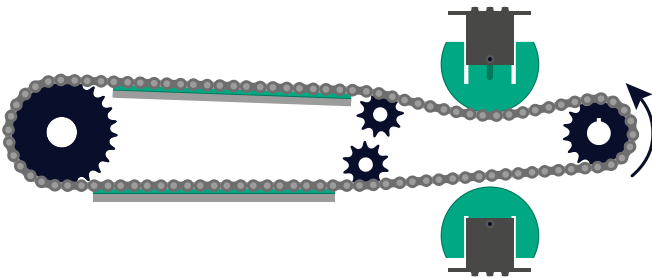

OMEGA TENSIONING STATION AS A READY-TO-INSTALL SYSTEM

Thanks to its double deflection, the Omega Tensioning Box® assembly provides twice the tensioning travel. This solution is ideal for use with long chain runs that have significant slack.

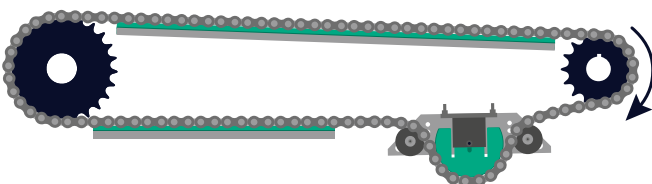

THE WEIGHT FORCE OF THE CHAIN

In the fully tensioned state, the weight force should not exceed the force of a spring that has already been compressed by 50%. Specific weight of common chains:

Chain 10B-1 = 0,91 kg/m

Chain 12B-1 = 1,18 kg/m

Chain 16B-1 = 2,68 kg/m

A COMBINATION

of rigid guide elements, slide rails, and a dynamically acting Spann-Box® provides the optimal tensioning solution for a chain drive.

CHALLENGE IN REVERSE OPERATION

Power transmission occurs exclusively in the load section. This is where the maximum tensile force is present, ensuring that there is no slack in this section of the chain and that the chain is therefore always fully tensioned. The resulting force acting perpendicular to the chain tensioner is always greater than the maximum tensioning force of the Spann-Box®. Consequently, the chain tensioner located in the load section leg is fully compressed, eliminating any springback effect. If this force acting on the Spann-Box® is too great, avoidable wear occurs on both the chain tensioner and the chain. Optimal positioning of the Spann-Box® is therefore crucial, especially in reversing operation.

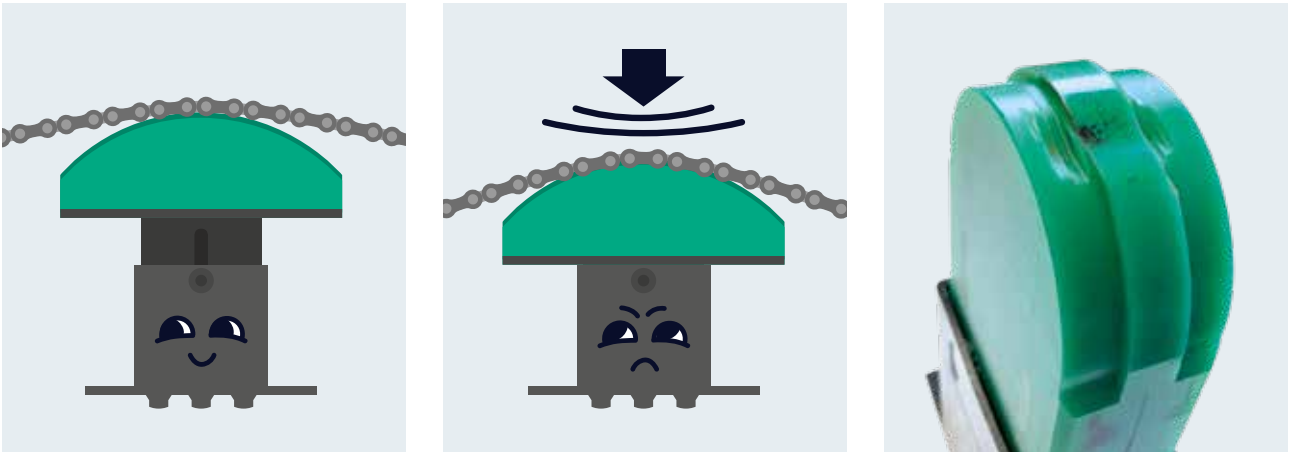

Possible wear patterns caused by overloading the Spann-Box®

CHAIN CONFIGURATION

1 = Minimum travel, 2 = Support slide rail, 3 = Support roller or slide shoe

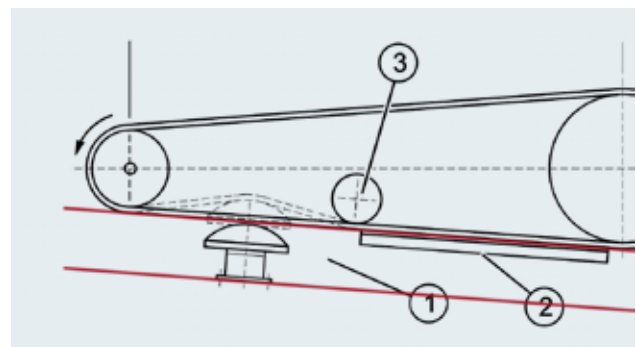
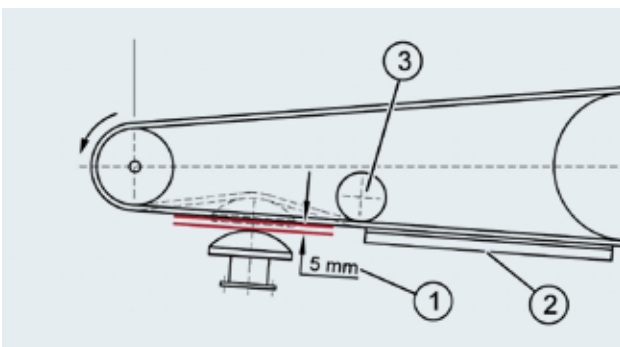

MINIMUM SPRING TRAVEL

The Mini-Spanner, Spann-Boy®, and Spann-Box® chain tensioners operate with spring action or free movement. To prevent increased surface pressure and the resulting heavy wear on the sliding surface, the chain tensioner should always have a minimum spring travel of 5 mm.

TANGENTIAL ALIGNMENT

The chain tensioner should be aligned parallel to the chain. Otherwise, there is a risk of uneven, one-sided wear.









03

Choosing the Right Chain Tensioning System

MURTFELDT tensioning systems operate with free movement and thus provide a spring-like effect. As a result, they do not act as a rigid deflection under load. They can tension both inward and outward. The following data are guidelines for the use of our chain and belt tensioners. We always recommend a customized assessment of your specific application.

MAXIMUM DRIVE SPEEDS

The maximum possible speeds depend heavily on the duty cycle. For a high duty cycle, the following applies: up to 1 m/s for standard "S"® green slide profiles; for higher speeds, Spann-Box® models with sprocket discs or slide profiles made of high-performance materials are available (up to 8 m/s).

	Name/Type	Maximum chain/belt speed
	Spann-Box® with a sliding profile	max. 1 m/s
	Spann-Twist	max. 1 m/s
	Spann-Box® Size 0 with reel	max. 3 m/s
	Spann-Box® Size 1 with reel	max. 8 m/s
	Spann-Box® Size 1, Type SR-L / SR-S with roller	max. 6 m/s
	Spann-Boy® TS with a roller	max. 6 m/s
	Spann-Box® Size 1, Type K-L / K-S with sprocket	max. 6 m/s
	Spann-Boy® TS with a sprocket	max. 6 m/s



THE FOLLOWING APPLIES TO OUR TENSIONING SYSTEMS:

Even when the full clamping stroke has been utilized, the clamping force is not exhausted – as a rule, at least 50% of the initial force remains effective.

PERMISSIBLE ENVIRONMENTAL CONDITIONS

Temperatures for standard models:
-40°C to 60°C with "S"® green sliding profile

Temperatures for custom models:
-40°C to 200°C with the appropriate plastic selection, as well as stainless steel springs and a stainless steel housing.

By selecting suitable materials for the sliding profile and the housing, our Spann-Box® range also **offers chemical and corrosion resistance.**

CLAMPING TRAVEL AND CLAMPING FORCE

To ensure the optimal amount of force is applied, we offer two different spring strengths (light and heavy), as well as the

option to adjust the tension individually by releasing individual springs.

Name/Type	Span in mm	Spring design	tensile strength 1 spring released	tensile strength 2 spring released	tensile strength 3 spring released
Mini-Spanner	16	light	–	19–13 N	–
		heavy	–	85–58 N	–
Spann-Box® Size 0	40	light	58–32 N	–	–
		heavy	132–60 N	–	–
Spann-Boy® TS	40	light	65–33 N	190–96 N	–
		heavy	125–63 N	–	–
Spann-Box® Size 1	40	light	58–32 N	116–64 N	174–96 N
		heavy	132–60 N	264–120 N	396–180 N
Spann-Box® Size 30	40	light	58–32 N	116–64 N	174–96 N
		heavy	132–60 N	264–120 N	396–180 N
Spann-Twist	60	light	42 N	–	–
		heavy	–	–	–
Spann-Box® Size 2	60	light	148–82 N	296–164 N	444–246 N
		heavy	262–116 N	524–236 N	786–354 N

BY LOOSENING INDIVIDUAL SPRINGS, YOU CAN ADJUST THE TENSION OF OUR CHAIN TENSIONERS.

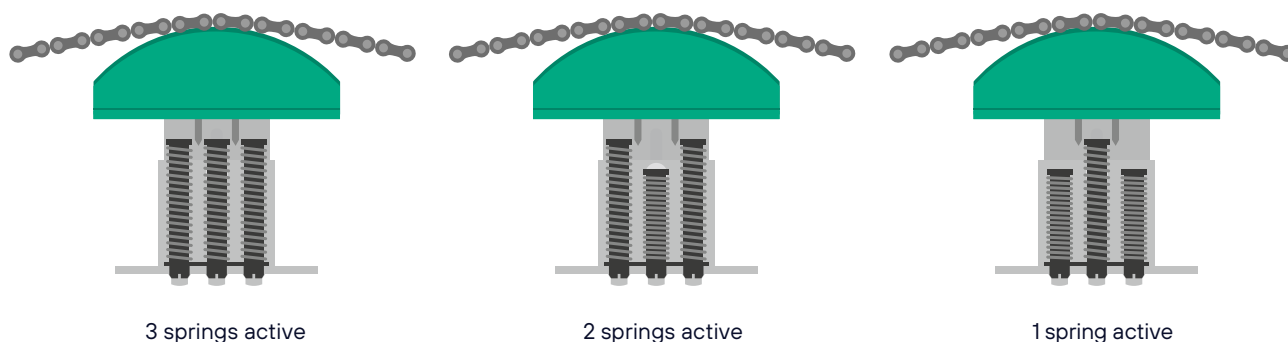

VISUAL INSPECTION INDICATOR PANELS

MURTFELDT Spann-Box® tensioning systems are equipped with a colored scale. This allows you to see at a glance the tension of the chain and thus determine whether the chain drive needs servicing.



GREEN

The chain tension is within the optimal operating range

YELLOW

The tension is no longer optimal, but still sufficient

RED

The chain tension is too low for smooth and safe operation. The chain tensioner must be readjusted.

DIFFERENCES IN TRACK PROFILES

Roller chains are typically tensioned on their rollers, which is why our slide profiles feature a track profile. This can be manufactured for simplex, duplex, and triplex chains. For smaller chains, it is also possible to use a U-profile.



U-channel



Tread Pattern
Simplex



Tread Pattern
Duplex



Tread Pattern
Triplex

OPTIONS FOR SLIDE PROFILES

With a range of geometries available for slide profiles, as well as idler pulleys and sprockets, we offer solutions for a wide variety of chain drives and tensioning applications.



ARC SEGMENT PROFILE

- + Mechanically optimal sliding profile shape
- + Simultaneous contact with multiple rollers
- + Optimal protection of the chain



SEMI-CIRCULAR PROFILE

- + For 90° turns
- + Contact with only a few chain rollers
- + Recommended for tight installation spaces



RETURN PROFILE

- + 180° deflection
- + The 180° deflection allows for double the utilization of the longer clamping stroke



BLOCK PROFILE

- + Suitable for particularly heavy chains and high inertial forces
- + Slide profile and clamping core manufactured as a single piece
- + No screw connections
- + High stability
- + 300 mm slide profile ensures support for multiple rollers in chains with larger pitch



ELLIPTICAL PROFILE

- + Elliptical chain slide profile with 180° swivel bearing
- + For use in chain drives with varying operating conditions
- + For applications where the chain drive angle changes
- + Ideal for highly dynamic chain drives



PULLEY/SPROCKET

- + For small deflections
- + At high chain speeds (> 1 m/s)

04

Advantages of the MURTFELDT Spann-Box®

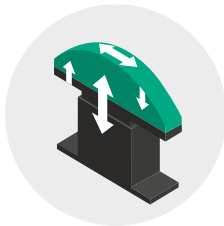

More responsive behavior in response to changes in chain movement

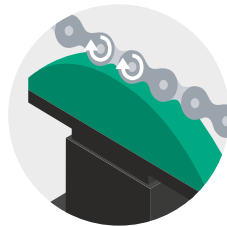

Reduction of wear on the chain links



Automatic adjustment for chain elongation

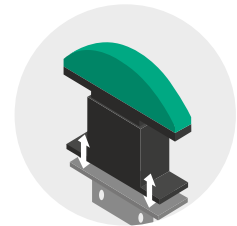

Easy installation and condition checks

The only system compliant with the Machinery Directive (EU) 2023/1230

ADVANTAGES OF MURTFELDT TENSIONING SYSTEMS

- ✓ Smooth chain operation
- ✓ Reduction of wear on the chain links
- ✓ Reduction of operating noise
- ✓ Automatic readjustment
- ✓ Compensating for chain and belt elongation
- ✓ Used as a chain and belt monitor
- ✓ Easy installation and adjustment
- ✓ Quick and reliable detection of the need for adjustment via sensors
- ✓ Much more dynamic response to changes in chain movement compared to versions with sluggish gas springs or other damping elements
- ✓ Standard solutions are available for almost all clamping applications



ADVANTAGES OF THE MURTFELDT PLASTICS USED

- ✓ Excellent sliding properties result in lower friction
- ✓ High wear resistance reduces maintenance intervals and the need for new investments
- ✓ Temperature resistance

With our wide range of tensioning systems, we can quickly and precisely meet virtually any requirement. If you're looking for a custom solution, our consulting service is available to assist you at any time, with no obligation.

Looking for the right tensioning system for your application?

REQUEST A QUOTE NOW!

Using our design questionnaire, you can provide us with your technical specifications so that we can offer you the best possible advice and help you choose the right solution. Please email us the completed questionnaire so that we can assist you as quickly as possible.

You can find the **design questionnaire** and **additional information** about our chain tensioning systems here:



Some of our chain tensioners for the machine and plant engineering industry already feature smart components for automated wear monitoring. Learn more about our tensioning systems with sensors at murtfeldt.de/en-GB

You can find a **detailed overview** of the available products in our catalog: murtfeldt.de/en-GB/Downloads/



QUESTIONS ABOUT OUR TENSIONING SYSTEMS?

We're happy to help.
Henning Müller
Tensioning Systems Expert / Specialist
Tension Systems originals@murtfeldt.de

MURTFELDT GmbH & Co. KG
Heßlingsweg 14-16
D-44309 Dortmund
Germany

Telefon: +49 (0)231 20609-0
Telefax: +49 (0)231 251021

E-Mail: info@murtfeldt.de

© 2026